TEK

**User Reference
Supplement**

**THE
11A72**
TWO-CHANNEL
AMPLIFIER

TEK

User Reference Supplement

Part No. 070-7255-00
Product Group 47

THE
11A72

TWO-CHANNEL
AMPLIFIER

Please check for CHANGE INFORMATION at the rear of this manual.

Tektronix
COMMITTED TO EXCELLENCE

Instrument Serial Numbers

Each instrument manufactured by Tektronix has a serial number on a panel insert, tag, or stamped on the chassis. The first letter in the serial number designates the country of manufacture. The last five digits of the serial number are assigned sequentially and are unique to each instrument. Those manufactured in the United States have six unique digits. The country of manufacture is identified as follows:

B010000	Tektronix, Inc., Beaverton, Oregon, USA
G100000	Tektronix Guernsey, Ltd., Channel Islands
E200000	Tektronix United Kingdom, Ltd., London
J300000	Sony/Tektronix, Japan
H700000	Tektronix Holland, NV, Heerenveen, The Netherlands

Instruments manufactured for Tektronix by external vendors outside the United States are assigned a two digit alpha code to identify the country of manufacture (e.g., JP for Japan, HK for Hong Kong, etc.).

Tektronix, Inc., P.O. Box 500, Beaverton, OR 97077

Copyright © Tektronix, Inc., 1989. All rights reserved. Tektronix products are covered by U.S. and foreign patents, issued and pending. The following are registered trademarks:

TEKTRONIX, INC., SCOPEMOBILE and



Centronics® is a registered trademark of the Data Computer Corporation.

TEKPROBE® is a registered trademark of Tektronix, Inc.

Contents

General Information	
Features	1-1
Contents of this Supplement	1-1
Safety Summary	1-2
Terms in Manuals	1-2
Terms on Equipment	1-2
Symbols in Manuals	1-2
Symbols on Equipment	1-2
Power Source	1-2
Grounding the Amplifier	1-2
Danger Arising from Loss of Ground	1-3
Do Not Operate in Explosive Atmospheres	1-3
Do Not Remove Covers or Panels	1-3
Compatibility of the Amplifier and the Mainframe	1-3
Initial Inspection	1-3
Operating Temperature	1-3
Installing and Removing the Amplifier	1-4
Affects of Coupling Mode on DC Circuit Loading	1-5
AC Coupling Mode	1-5
Off Coupling Mode	1-5
DC Coupling Mode	1-6
Overdrive Recovery	1-6
Instrument Options	1-6
Operation in Analog Oscilloscopes	
Display On/Off	2-1
Functions Controlled by the Oscilloscope	2-1
Sensitivity and Offset	2-1
Coupling	2-2
Adding Waveforms	2-2
50 Ω Overload	2-2
Front Panel Error Messages	2-2
GPIB and RS-232-C Commands and Syntax	2-3
Operation in Digitizing Oscilloscopes	
Display On/Off	3-1
Functions Controlled by the Oscilloscope	3-1
Sensitivity and Offset	3-1
Adding and Subtracting Waveforms	3-2
50 Ω Overload	3-2
Front Panel Error Messages	3-3
GPIB and RS-232-C Commands and Syntax	3-4
Specifications	
Performance Conditions	4-1
System Specifications	4-5

List of Illustrations

Figure 1-1	Installing and Removing an Amplifier	1-4
Figure 1-2	Location of AC Coupling Capacitors In Plug-in Amplifiers . . .	1-5
Figure 4-1	Dimensions of the 11A72 Amplifier	4-4

List of Tables

Table 2-1	CH Command Links	2-3
Table 2-2	CH Command Query-Only Links	2-3
Table 3-1	CH Command Links	3-4
Table 3-2	CH Command Query-Only Links	3-4
Table 4-1	Electrical Characteristics	4-1
Table 4-2	Environmental Characteristics	4-3
Table 4-3	Physical Characteristics	4-4
Table 4-4	Electrical Characteristics of the 11A72 Amplifier in 11300-Series Oscilloscopes	4-5
Table 4-5	Electrical Characteristics of the 11A72 Amplifier in 11400-Series Oscilloscopes	4-7

General Information

This supplement to the *User Reference* manual for your mainframe describes the features and operation of the Tektronix 11A72 Two-Channel Amplifier. The *11A72 Service Reference* manual provides service information and test procedures for the 11A72 Amplifier.

Functions common to all plug-in amplifiers, such as offset, sensitivity, input impedance and coupling, are described in the *User Reference* for each mainframe. This manual discusses the performance of systems that are configured using the 11A72 Amplifier.

Features

- DC to 1 GHz bandwidth (system bandwidth also depends on mainframe)
- Dual channel
- Calibrated sensitivities from 10 mV to 1 V/div
- 50 Ω input impedance
- High-resolution, calibrated DC offset (0.25 div/increment, coarse; 0.025 div/increment, fine)
- Fast overdrive recovery
- Coupling: AC, DC, or Off
- Display Polarity: normal or inverted

Contents of this Supplement

This supplement contains the following sections:

- General Information provides information about the compatibility of the 11A72 Amplifier with 11000-Series Oscilloscopes, how to install and remove the amplifier, the operating temperature of the amplifier, the affect of input coupling node on DC circuit loading, and the options available for the amplifier.
- Operation in Analog Oscilloscopes explains how to operate the amplifier in 11000-Series Analog Oscilloscopes.
- Operation in Digitizing Oscilloscopes explains how to operate the amplifier in 11000-Series Digitizing Oscilloscopes.
- Specifications lists electrical, environmental and physical specifications of the amplifier.

Safety Summary

This general safety information applies to all operators and service personnel. Specific warnings and cautions will be found throughout the supplement where they apply, but may not appear in this summary.

Terms in Manuals

CAUTION statements identify conditions or practices that could result in damage to the equipment or other property.

WARNING statements identify conditions or practices that could result in personal injury or loss of life.

Terms on Equipment

CAUTION indicates a personal injury hazard not immediately accessible as one reads the marking, or a hazard to property including the equipment itself.

DANGER indicates a personal injury hazard immediately accessible as one reads the marking.

Symbols in Manuals



Static Sensitive Devices

Symbols on Equipment



DANGER
High Voltage



*Protective
ground (earth)
terminal*



ATTENTION
*Refer to
manual*

Power Source

This amplifier is intended to operate in a mainframe connected to a power source that will not apply more than 250 V rms between the supply conductors or between either supply conductor and ground. A protective ground connection, through the grounding conductor in the mainframe power cord, is essential for safe system operation.

Grounding the Amplifier

This amplifier is grounded through the grounding conductor of the mainframe power cord. To avoid electric shock, plug the mainframe power cord into a properly wired receptacle before installing the amplifier. A protective ground connection, through the grounding conductor in the mainframe power cord, is essential for safe operation.

Danger Arising from Loss of Ground

Upon loss of the protective ground connection, all accessible conductive parts (including knobs and controls that may appear to be insulators), can render an electric shock.

Do Not Operate in Explosive Atmospheres

To avoid explosion, do not operate this product in an atmosphere of explosive gasses.

Do Not Remove Covers or Panels

To avoid personal injury, do not operate this amplifier without the panels or covers. Operating the amplifier without the covers in place may cause overheating and damage to the amplifier.

Compatibility of the Amplifier and the Mainframe

The 11A72 Amplifier is designed for use in 11000-Series oscilloscopes. Amplifier bandwidth varies depending on the mainframe. Vertical accuracy depends on both the mainframe and any probes used. Details about bandwidth and vertical accuracy are included in System Specifications. Refer to the Tektronix Corporate Catalog for complete information about compatibility of amplifiers and mainframes.

Initial Inspection

After unpacking, inspect the amplifier and look for physical damage that may have occurred in transit. This amplifier was inspected mechanically and electrically before shipment, and should meet all electrical specifications. To verify that the amplifier is functioning properly you can perform the Checks and Adjustment procedures in the *11A72 Service Reference* manual. If you find that the amplifier is damaged or deficient, contact your local Tektronix field office or representative, and again refer to the Packaging for Shipment instructions in the *11A72 Service Reference* manual.

Operating Temperature

The 11A72 Amplifier can be operated where the ambient air temperature is between 0° and +50°C and can be stored in ambient temperatures from -40° to +75°C. If stored at temperatures outside the operating limits, allow the chassis to reach operating temperature limits before applying power.

Installing and Removing the Amplifier

CAUTION

To install the amplifier in the mainframe, set the mainframe ON/STANDBY switch to STANDBY. Align the grooves in the top and bottom of the amplifier with the guides in the mainframe plug-in compartment, then insert the amplifier into the mainframe until its front panel is flush with the front panel of the mainframe. (See Figure 1-1.)

Always set the mainframe ON/STANDBY switch to STANDBY before installing or removing the amplifier. This will prevent damage to the amplifier of the mainframe.

If the green indicator light remains ON when the STANDBY position is selected, the switch has been internally disabled. To remove or reinstall amplifier units in this case, use the mainframe PRINCIPAL POWER SWITCH (rear panel) to shut OFF the power. This will prevent damage to either the amplifier or the mainframe.

To enable the ON/STANDBY switch, refer the mainframe to qualified service personnel.

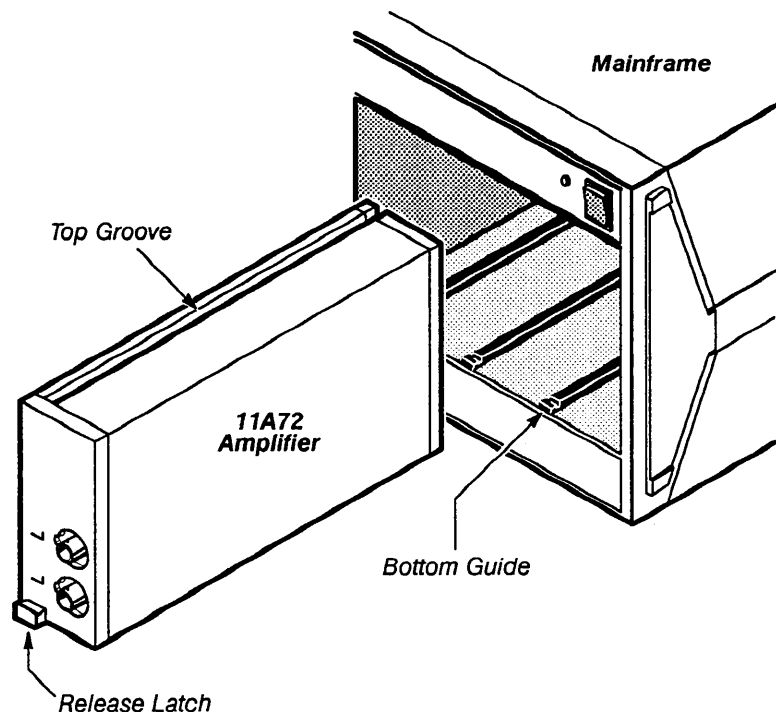

Figure 1-1 — Installing and Removing an Amplifier

To remove the amplifier from the mainframe, set the mainframe ON/STANDBY switch to STANDBY. Then pull the release latch to disengage the amplifier from the mainframe, and pull the amplifier straight out of the compartment.

Affects of Input Coupling Mode on DC Circuit Loading

The AC coupling capacitor of the 11A72 Amplifier isolates both the input termination and the amplifier from external DC voltages. You can use the 11A72 Amplifier with AC coupling selected to safely test circuits that would be damaged by a $50\ \Omega$ load. Avoid inadvertently selecting DC coupling if your circuit will be damaged by the resulting $50\ \Omega$ termination to ground.

The input circuits of the 11A52 and 11A71 Amplifiers are similar to that of the 11A72 Amplifier. In other amplifiers, including the 11A32, 11A33, and 11A34 Amplifiers, the AC coupling capacitor does not isolate the input termination from external DC voltages, and will not protect a low-impedance circuit. Figure 1-2 shows these two types of amplifier input circuits.

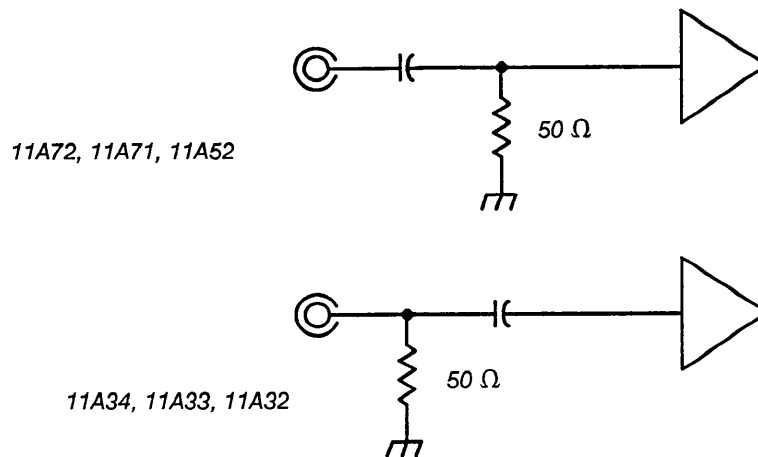

Figure 1-2 – Location of AC Coupling Capacitors In Plug-in Amplifiers

AC Coupling Mode

When AC Coupling is selected, you can test low-impedance circuits that are elevated in potential by up to 100 V DC without loading the circuit at DC. Passive attenuating probes such as the P6156 or P6057 probes reduce the AC loading and lower the low-frequency -3 dB point.

An active probe, such as the P6204 probes, eliminates the possibility of AC coupling. When an active probe is used, the coupling options are Off and DC.

Off Coupling Mode

When coupling is Off, the AC coupling capacitor charges in about three seconds to the average DC voltage at the amplifier input. Always use the Off mode when connecting the amplifier input to a circuit that may have more than 25 V (the 11A72 Amplifier's peak input voltage rating) present. This will precharge the coupling capacitor. Wait a few seconds before selecting AC coupling. The coupling capacitor is discharged upon disconnection from the external circuit.

DC Coupling Mode

When DC coupling is selected, a 50 Ω termination resistance is connected directly from the amplifier input connector to ground.

Two ways of unintentionally invoking DC coupling in the amplifier are:

- Selecting Autoset, because the autoset process of most oscilloscopes starts by searching for a DC voltage
- Recalling a stored setting that dictates DC coupling.



Always use caution when working with voltages in excess of 25 V.

Switching coupling to DC when more than 25 V is present at the amplifier input will exceed the peak input voltage specification, and may damage the amplifier's input relay. A damaged relay could cause an error in calibration.

Take care that the circuit connected to the 11A72 Amplifier input will not be damaged by the 50 Ω load.

Overdrive Recovery

Overdrive occurs whenever an amplifier is driven out of its linear range of ± 15 divisions. The overdrive recovery of an amplifier is the time it takes the amplifier to settle to within a stated fraction of the equilibrium value after an input step.

At all vertical settings the 11A72 amplifier typically settles in less than 20 nanoseconds to within 2% of the signal amplitude ± 0.1 division. This applies only for input signals up to ± 1 volt in amplitude.

You can use the overdrive recovery capability of the 11A72 Amplifier to extend measurement resolution. For example, if a signal changes from -0.8 V to $+0.2$ V in 20 ns, you can use the amplifier to determine if the signal stabilized immediately at $+0.2$ V or if it had some small aberration following the transition. By setting the offset to $+0.2$ V and the sensitivity to 10 mV/division, aberrations of just 1% of the original transition will be 1.0 division in amplitude (1% of 1.0 V is 10 mV, or 1.0 divisions at 10 mV/division).

Instrument Options

Option 01 – SMA input connectors.

Option 25 – adds two P6231 probes.

Option 26 – adds two P6203 probes.

Option 27 – adds two P6204 probes.

Operation in Analog Oscilloscopes

This section discusses using the 11A72 Amplifier in 11000-Series Analog Oscilloscopes.

Display On/Off

The amplifier has a display on/off button next to each input channel. Pressing this button displays or removes the channel signal from the oscilloscope display. When a channel is displayed, its label is lighted.

Functions Controlled by the Oscilloscope

Most functions of the amplifier are controlled by the oscilloscope, and their operation is described in the *User Reference* manual for the oscilloscope. Specifically, the oscilloscope controls the following functions:

- Sensitivity (Vertical Size)
- Offset
- Coupling (AC, DC, Off)
- Displaying or Selecting Channel
- Display Polarity
- Trigger Selection

When the amplifier is installed in the center or right compartment of an 11000-Series Analog Oscilloscope it provides the X (horizontal) component of an XY display, or it provides a trigger signal for the time base of the oscilloscope.

Sensitivity and Offset

To set the amplifier sensitivity or offset, press the VERTICAL SENSITIVITY or VERTICAL OFFSET button on the oscilloscope and change the sensitivity or offset value using the control knobs.

Offset subtracts the specified voltage from the input signal. When offset changes, the position of the waveform on the display changes. Do not confuse vertical offset with vertical position, which is a display feature of the oscilloscope. You can use vertical position to place each waveform on a different graticule line. The Vertical Position control has a range of ± 4 divisions from graticule center. The Offset control is expressed in volts and has a range equal to ± 25 divisions, that is, ± 25 (deflection factor) volts.

Changing the sensitivity increases or decreases the the vertical size of the channel display around the screen level that is determined by the Vertical Position. If you change the sensitivity setting and the displayed waveform becomes larger than the screen, the area of the waveform you wish to view may be off-screen. Use the Offset control to bring the area of interest to the screen location you established with the Vertical Position control.

Coupling

To set the amplifier's input coupling:

1. Select a displayed waveform.
2. Display the Control Menu using the control menu buttons. Refer to the oscilloscope *User Reference* manual under the topic Control Menus for more information.
3. Touch the Coupling label to change the amplifier coupling.

Adding Waveforms

11000-Series analog oscilloscopes allow the addition of any two displayed channels. Each channel must be in its linear operating range, which is assured if each channel is displayed within the screen area before the channels are combined.

Portions of a waveform that are off-screen will not be valid when brought back on-screen using another channel's input signal or offset. This general restriction applies to any two-channel analog oscilloscope.

50 Ω Overload

When the input voltage substantially exceeds 5 V rms, the amplifier will disconnect the 50 Ω input termination, and the oscilloscope will display the message:

Input channel N overload on LEFT/CENTER/RIGHT plug-in

where N = 1 or 2.

To reconnect the 50 Ω input termination, first correct the overload condition, then select AC or DC coupling.

Front Panel Error Messages

When an error occurs involving a plug-in amplifier, the oscilloscope will display an error message.

For example, the following error messages may appear on the oscilloscope display:

Internal DAC overflow on channel N of LEFT/CENTER/RIGHT plug-in unit

A plug-in amplifier detected that a requested setting overflowed an internal DAC. Such overflow usually indicates defective hardware. In this situation, the amplifier sets the DAC to the limit closer to the requested setting.

Bad Level 2 probe checksum on channel N of LEFT/CENTER/RIGHT plug-in unit

A plug-in amplifier detected that a Level 2 TEKPROBE failed or was improperly connected.

Requested Coupling not available on Channel N of LEFT/CENTER/RIGHT plug-in unit

A plug-in amplifier detected that a Level 2 TEKPROBE failed or was improperly connected during either autoset or probe calibration.

**GPIB and RS-232-C
Commands and
Syntax**

The CH (Channel) command sets the parameters of a specified channel.

CH {**L**|**C**|**R**}{**1**|**2**} <link>:<argument>

Table 2-1 and Table 2-2 list the links and arguments of the CH command.

Table 2-1 – CH Command Links

Link	Argument	Argument Ranges		
BWHi:	<NRx>	HF Limit (when queried) 11301, 11301A Oscilloscope: 400E+6 11302, 11302A Oscilloscope: 500E+6		
COUpling:	AC DC OFF			
IMPedance:	<NRx>	50		
OFFSet: ¹	<NRx>	Volts/div	Offset Range	Resolution
		10 mV	±250 mV	250E-6V
		20 mV	±500 mV	500E-6V
		50 mV	±1.25 V	1.25E-3V
		100 mV	±2.5 V	2.5E-3V
		200 mV	±5 V	5.0E-3V
		500 mV	±12.5 V	12.5E-3V
		1 V	±25 V	25E-3V
		Resolution is for GPIB, RS-232-C, or numeric entry.		
SENSitivity:	<NRx>	10E-3, 20E-3, 50E-3, 100E-3, 200E-3, 500E-3, 1 The numbers listed are those available at the input connectors. Connecting an attenuating probe will change the value proportional to the probe's attenuation factor.		

Table 2-2 – CH Command Query-Only Links

Query-only Link	Response	Meaning
? PRObe	<qstring>	Returns a description of the probe connected to the channel. For a Level 1 TEKPROBE, the query returns "Level 1." For a Level 2 TEKPROBE, the query returns "Level2/ <probe_type>/ <serial_number>." When no TEKPROBE is connected, the query returns "NONE."
? UNIts	<qstring>	Returns the units of conversion of a probe connected to the specified channel input.

Operation in Digitizing Oscilloscopes

This section discusses using the 11A72 Amplifier in 11000-Series Digitizing Oscilloscopes.

Display On/Off

The amplifier has a display on/off button next to each input channel. Pressing the button turns display of the channel on or off. The label next to the button is lighted whenever the channel is displayed. Display of a channel can also be turned on or off from the oscilloscope front panel.

Functions Controlled by the Oscilloscope

Most functions of the amplifier are controlled by the oscilloscope, and their operation is described in detail in the *User Reference* manual for the oscilloscope. The oscilloscope controls the following functions:

- Sensitivity (Vertical Size)
- Offset (Vertical Position)
- Coupling (AC, DC, Off)
- Displaying or Selecting Channel
- Display Polarity
- Trigger Selection

Sensitivity and Offset

Digitizing oscilloscopes use offset to position the waveform on the screen. In Yt (signal vs. time) mode, offset determines vertical position, but when the amplifier provides the X component of an XY display, offset determines horizontal position.

Offset, or Vertical Position, subtracts a specified voltage from the input signal. Sensitivity, or Vertical Size, magnifies or compresses the signal about the vertical center of the graticule. To control these functions, touch the vertical icon on the oscilloscope display and adjust the Vertical Position or Vertical Size using the control knobs.

Adding and Subtracting Waveforms

Addition and subtraction of input signals is controlled by the oscilloscope. The individual channels need not be displayed before entering a waveform description that combines them. Touch the **DefWfm** icon on the display and enter the waveform description using the **Vertical Description** pop-up menu. See the *User Reference* manual for your oscilloscope for more information on this method of entering a complex waveform description.

When you are adding or subtracting waveforms, it is better to add or subtract signals from channels of separate plug-in amplifiers, rather than multiple channels of the same plug-in amplifier. Samples from one channel of each plug-in compartment will be acquired simultaneously, but multiple channels from the same plug-in compartment are taken at different times, so a complex waveform that is composed of multiple channels from the same plug-in amplifier may not accurately reflect the combination of the input signals. Signals that are entirely repetitive and related to the trigger signal may be added or subtracted accurately in spite of being sampled at different times.

The best common-mode rejection can be obtained using a differential plug-in amplifier.

Even when using channels from different plug-in compartments, the following two problems limit the accuracy of sums or differences:

- Step 1: Each waveform in memory is constantly being updated, and therefore some waveform points are "older" than others. Although samples may be taken simultaneously, there is a chance that a sample may be replaced in memory with a newer value before the waveform is processed and displayed.
- Step 2: Delay differences between channels of different plug-in amplifiers due to probe cable length differences are normally removed by deskewing the probes and the associated amplifier channels. Samples are still taken simultaneously, but the display is manipulated to correct for timing differences. Signals directly related to the trigger signal are correctly restored to their proper time relationship, but there is no way for signals unrelated to the trigger to be corrected with this deskewing technique. High-frequency rejection of signals unrelated to the trigger is not improved by deskewing.

The solution to both problems is to invoke averaging. Averaging suppresses signals and noise unrelated to the trigger.

50 Ω Overload

When the input voltage substantially exceeds 5 V rms, the amplifier will disconnect the 50 Ω input termination, and the oscilloscope will display the message:

Input channel N overload on LEFT/CENTER/RIGHT plug-in

where N = 1 or 2.

To reconnect the 50 Ω input termination, first correct the overload condition, then select AC or DC coupling.

Front Panel Error Messages

When an error occurs involving a plug-in amplifier, the oscilloscope will display an error message.

For example, the following error messages may appear on the oscilloscope display:

Internal DAC overflow on channel N of LEFT/CENTER/RIGHT plug-in unit

A plug-in amplifier detected that a requested setting overflowed an internal DAC. Such overflow usually indicates defective hardware. In this situation, the amplifier sets the DAC to the limit closer to the requested setting.

Bad Level 2 probe checksum on channel N of LEFT/CENTER/RIGHT plug-in unit

A plug-in amplifier detected that a Level 2 TEKPROBE failed or was improperly connected.

Requested Coupling not available on Channel N of LEFT/CENTER/RIGHT plug-in unit

A plug-in amplifier detected that a Level 2 TEKPROBE failed or was improperly connected during either autoset or probe calibration.

**GPIB and RS-232-C
Commands and
Syntax**

The CH (Channel) command sets the parameters of a specified channel.

CH {L|C|R}{1|2} <link>:<argument>

Table 3-1 and Table 3-2 list the links and arguments of the CH command.

Table 3-1 – CH Command Links

Link	Argument	Argument Ranges																								
BWHI:	<NRx>	HF Limit (when queried) 11401 Oscilloscope: 500E+6 11402 Oscilloscope: 1.0E+9																								
COUpling:	AC DC OFF																									
IMPedance:	<NRx>	50																								
OFFSet:¹	<NRx>	<table border="1"> <thead> <tr> <th>Volts/div</th> <th>Offset Range</th> <th>Resolution</th> </tr> </thead> <tbody> <tr> <td>10 mV</td> <td>±250 mV</td> <td>250E-6V</td> </tr> <tr> <td>20 mV</td> <td>±500 mV</td> <td>500E-6V</td> </tr> <tr> <td>50 mV</td> <td>±1.25 V</td> <td>1.25E-3V</td> </tr> <tr> <td>100 mV</td> <td>±2.5 V</td> <td>2.5E-3V</td> </tr> <tr> <td>200 mV</td> <td>±5 V</td> <td>5.0E-3V</td> </tr> <tr> <td>500 mV</td> <td>±12.5V</td> <td>12.5E-3V</td> </tr> <tr> <td>1 V</td> <td>±25 V</td> <td>25E-3V</td> </tr> </tbody> </table> <p>Resolution is for GPIB, RS-232-C, or numeric entry.</p>	Volts/div	Offset Range	Resolution	10 mV	±250 mV	250E-6V	20 mV	±500 mV	500E-6V	50 mV	±1.25 V	1.25E-3V	100 mV	±2.5 V	2.5E-3V	200 mV	±5 V	5.0E-3V	500 mV	±12.5V	12.5E-3V	1 V	±25 V	25E-3V
Volts/div	Offset Range	Resolution																								
10 mV	±250 mV	250E-6V																								
20 mV	±500 mV	500E-6V																								
50 mV	±1.25 V	1.25E-3V																								
100 mV	±2.5 V	2.5E-3V																								
200 mV	±5 V	5.0E-3V																								
500 mV	±12.5V	12.5E-3V																								
1 V	±25 V	25E-3V																								
SENSitivity:	<NRx>	10E-3, 20E-3, 50E-3, 100E-3, 200E-3, 500E-3, 1 The numbers listed are those available at the input connectors. Connecting an attenuating probe will change the value proportional to the probe's attenuation factor.																								

Table 3-2 – CH Command Query-Only Links

Query-only Link	Response	Meaning
? PRObe	<qstring>	Returns a description of the probe connected to the channel. For a Level 1 TEKPROBE, the query returns "Level 1." For a Level 2 TEKPROBE, the query returns "Level2/ <probe_type>/ <serial_number>." When no TEKPROBE is connected, the query returns "NONE."
? UNIts	<qstring>	Returns the units of conversion of a probe connected to the specified channel input.

Specifications

Performance Conditions

The specifications in Tables 4-1, 4-2, and 4-3 apply to the 11A72 Amplifier in all mainframes. These specifications apply when the mainframe is in the Enhanced Accuracy state. System specifications that depend on the type of mainframe and probes used are listed in System Specifications, later in this section.

Enhanced Accuracy is initiated by pushing the Enhanced Accuracy button on the mainframe after the system has reached thermal equilibrium, which requires a 20-minute warmup. Enhanced Accuracy is indicated on the display and remains in effect as long as the internal temperature of the mainframe is within $\pm 5^{\circ}\text{C}$ of the temperature at which the calibration was performed. When a 5°C change does occur, the system reverts to Normal accuracy. In the Normal accuracy condition, those characteristics that are temperature sensitive may not remain within the limits of these specifications. The specifications are valid at an ambient temperature of 0° to 50°C , unless otherwise stated.

Table 4-1 – Electrical Characteristics

Function	Characteristic	Performance Requirement
Offset	Accuracy	Refer to System Specifications
	Range	± 25 divisions
	Resolution	Coarse: 0.25 divisions Fine: 0.025 divisions
Input	Maximum Input Voltage, AC or DC Coupled	5 V rms (0.5 W) or 0.25 watt-second pulses not exceeding 25 V peak
	Maximum DC Input Voltage, AC Coupled	± 100 V DC (DC + peak AC) <i>CAUTION: Signals of more than 25 V peak amplitude must be connected with the input coupling set to Off so that the input coupling capacitor is precharged.</i>
	Input Disconnect Threshold	5 V rms typical (from DC to 100 MHz)
	Power-Down Impedance	500 k Ω $\pm 10\%$ when powered down
	Impedance (DC coupled)	50 Ω within 0.5%, Voltage standing wave ratio $\leq 1.45:1$ at 10 mV/div, DC to 1 GHz Voltage standing wave ratio $\leq 1.25:1$ at 20 mV/div to 1 V/div, DC to 1 GHz

Table 4-1 – Electrical Characteristics (cont)

Function	Characteristic	Performance Requirement
Input (cont)	Impedance (AC coupled)	50 Ω within 0.5%, in series with nominally 2.2 μF Voltage standing wave ratio ≤1.45:1 at 10 mV/div, 10 MHz to 1 GHz Voltage standing wave ratio ≤1.25:1 at 20 mV/div to 1 V/div, 10 MHz to 1 GHz
	Impedance Bias Current	≤10.0 μA
Miscellaneous	Typical Noise	RMS noise: 0.022 divisions at 10 mV/div to 1 V/div
	Channel Isolation	At least 40:1 display ratio ¹ for DC to 1 GHz at any sensitivity
	Common Mode Rejection Ratio	At least 20:1, for DC to 50 MHz at any sensitivity with 10 division reference signal on each channel.
	Probe Compatibility	Compatible with Level 1 and Level 2 TEKPROBES ²
Step Response	Overdrive Recovery Time	Typically < 20 ns to within 2% of signal + 0.1 division. At sensitivities ≥10 mV/div, for signals up to ±1 V peak.

$${}^1\text{Display ratio} = \frac{\text{Amplitude(V)(driven channel)}}{\text{V/div (driven channel)}} \bigg/ \frac{\text{Error Amplitude(V)(undriven channel)}}{\text{V/div (undriven channel)}}$$

²TEKPROBE is the Tektronix name for the interface used with probes that are designed for the 11000-Series of oscilloscopes and amplifiers. TEKPROBES have output connectors with one or more spring-loaded coding pins.

The Level 1 TEKPROBE uses analog encoding to communicate the probe's scale factor to the amplifier.

The Level 2 TEKPROBE uses an EEPROM to store data about the probe's transfer units, scale factor, and output voltage scale factor.

Table 4-2 – Environmental Characteristics

Characteristic	Information
Ambient temperature (External to mainframe)	
Operating	0° to +50°C, mainframe ambient
Nonoperating	-40° to +75°C
Humidity, Operating and Non-operating	Meets MIL-T-28800C, Type III, class 5 as described in 3.9.2.2 and 4.5.5.1.2.2
Altitude	
Operating	To 4,570m (15,000 ft.)
Nonoperating	To 15,200m (50,000 ft.)
Vibration	
Operating, installed on Flexible Extender	MIL-T-28800C, Sec. 4.5.5.3.1, Type III, class 5
Shock, Nonoperating (not installed in mainframe)	MIL-T-28800C, Sec. 4.5.5.4.1, Type III, class 5
Bench Handling (operating and nonoperating)	MIL-T-28800C, Sec. 4.5.5.4.3, Type III, class 5
Packaged Product Vibration and Shock	
Vibration and bounce of Packaged Product	Meets ASTM D999-75, Method A, Paragraph 3.1 (NSTA Project 1A-B-1)
Drop of Packaged Product	Meets ASTM D775-61, Method 1, Paragraph 5 (NSTA Project 1A-B-2)
Electromagnetic Compatibility	MIL-STD-461BFCC Part 15, Subpart J, Class A VDE 0871/6.78, Class B

Table 4-3 – Physical Characteristics

Characteristic	Information
Weight (max)	1 lb. 14 oz (851 g)
Weight of Packaged Product (max)	4 lb. 12 oz. (2.2 kg)
Dimensions (max)	See Figure 4-1

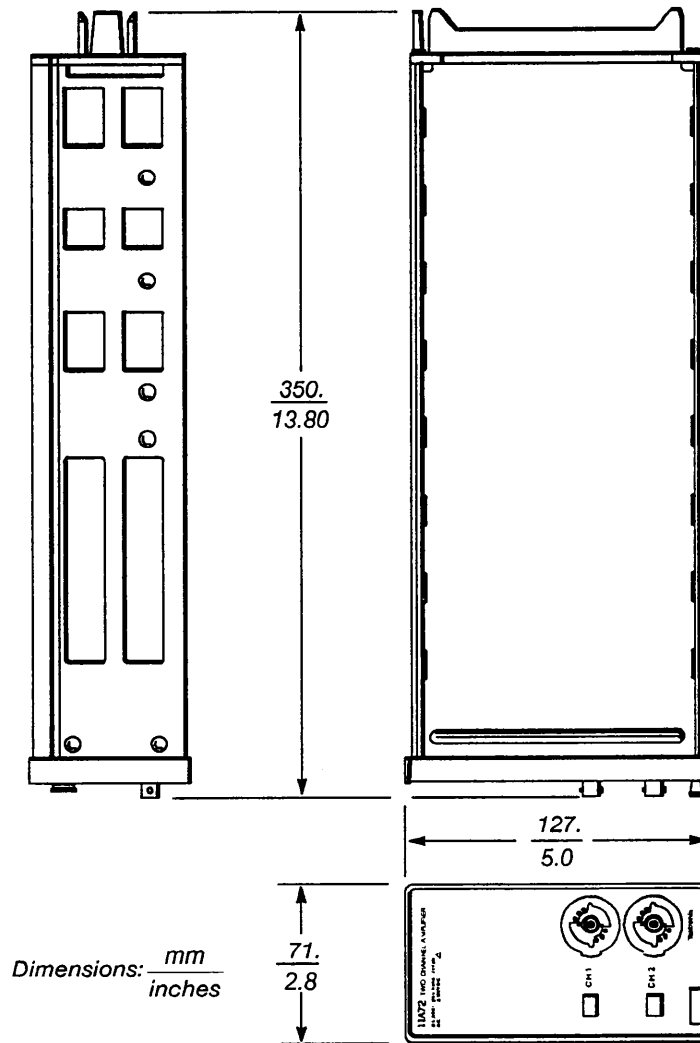

Figure 4-1 – Dimensions of the 11A72 Amplifier

System Specifications

System specifications depend on the combination of mainframe, amplifier and probe. Tables 4-4 and 4-5 contain the specifications of the system consisting of the mainframe, the 11A72 Amplifier, and probes (if any). Tables 4-4 and 4-5 contain information relating to the ΔV DC Accuracy, DC Offset Accuracy, DC Balance, and bandwidth of the system.

Table 4-4 — *Electrical Characteristics of the 11A72 Amplifier in 11300-Series Oscilloscopes*

Characteristic	Performance Requirement			
Deflection Factor (Sensitivity)	Calibrated Range: Enhanced DC Accuracy ¹ , either polarity, with on-screen cursors. The calibrated range is 10 mV/div to 1 V/div.			
	Without Probes			
	Volts/Division	ΔV DC Accuracy	DC Balance	DC Offset Accuracy
	10 mV to 1 V	$\pm(0.8\% + 0.03 \text{ div})$	$\pm 0.1 \text{ div}$	$\pm(0.4\% + 0.01 \text{ div})$
	With P6231 Probe calibrated from 11300-Series Oscilloscope Calibrator output. Probe Tip TC 100 ppm/°C			
	Volts/Division	ΔV DC Accuracy	DC Balance	DC Offset Accuracy
	10 mV to 1 V	$\pm(1.2\% + 0.03 \text{ div})$	$\pm 0.1 \text{ div}$	$\pm(0.15\% + 2 \text{ mV})$
	With P6204 Probe calibrated from 11300-Series Oscilloscope Calibrator output. Probe Tip TC 100 ppm/°C			
	Volts/Division	ΔV DC Accuracy	DC Balance	DC Offset Accuracy
	100 mV to 10 V/div	$\pm(0.8\% + 0.03 \text{ div})$	$\pm(5 \text{ mV} + 0.1 \text{ div})$	$\pm(0.15\% + 4 \text{ mV})$
	With P6156 Probe calibrated from 11300-Series Oscilloscope Calibrator output. With Option 26, 500 Ω 10X Probe Tip.			
	Volts/Division	ΔV DC Accuracy	DC Balance	DC Offset Accuracy
	100 mV to 10 V/div	$\pm(1.0\% + 0.05 \text{ div})$	$\pm 0.2 \text{ div}$	$\pm(0.50\% + 0.01 \text{ div})$
	With P6156 Probe calibrated from 11300-Series Oscilloscope Calibrator output. With Option 27, 1000 Ω 20X Probe Tip.			
	Volts/Division	ΔV DC Accuracy	DC Balance	DC Offset Accuracy
200 mV to 20 V/div	$\pm(1.0\% + 0.05 \text{ div})$	$\pm 0.2 \text{ div}$	$\pm(0.50\% + 0.01 \text{ div})$	
With P6156 Probe calibrated from 11300-Series Oscilloscope Calibrator output. With Option 28, 5000 Ω 100X Probe Tip.				
Volts/Division	ΔV DC Accuracy	DC Balance	DC Offset Accuracy	
1 V/div	$\pm(1.0\% + 0.05 \text{ div})$	$\pm 0.2 \text{ div}$	$\pm(0.50\% + 0.01 \text{ div})$	
2 V to 100 V/div	$\pm(2.0\% + 0.05 \text{ div})$	$\pm 0.2 \text{ div}$	$\pm(1.50\% + 0.01 \text{ div})$	

¹For absolute DC accuracy of single-point measurements using Offset, add the DC Offset Accuracy, DC Balance and ΔV DC Accuracy terms. ΔV DC Accuracy applies to the difference between the Vertical Position setting and the measurement point.

Table 4-4 – Electrical Characteristics of the 11A72 Amplifier in 11300-Series Oscilloscopes (cont)

Characteristic	Performance Requirement	
Frequency Response	High Frequency Limit (-3 dB point) and Calculated Rise Time for the Display, Auxiliary and Trigger signals. Low Frequency -3 dB point: 1 kHz maximum from 50 Ω source with AC coupling (V DC \leq 20 V), temperature 0°C to 30°C	
	Volts/Division	11301, 11301A Oscilloscope
All	400 MHz Bandwidth 0.9 ns Calc Rise time	500 MHz Bandwidth 0.7 ns Calc Rise time

Table 4-5 – Electrical Characteristics of the 11A72 Amplifier in 11400-Series Oscilloscopes

Characteristic	Performance Requirement			
Deflection Factor (Sensitivity)	Calibrated Range: Enhanced DC Accuracy ¹ , either polarity. The calibrated range is 1 mV/div to 10 V/div.			
	Without Probes			
	Volts/Division	ΔV DC Accuracy	DC Balance	DC Offset Accuracy
	10 mV to 1 V	±(0.6% + 0.01 div)	±0.1 div	±(0.4% + 0.01 div)
	With P6231 Probe calibrated from 11400-Series Oscilloscope Calibrator output. Probe Tip TC 100 ppm/°C			
	Volts/Division	ΔV DC Accuracy	DC Balance	DC Offset Accuracy
	100 mV to 1 V	±(1.0% + 0.01 div)	±0.1 div	±(0.15% + 2 mV)
	With P6204 Probe calibrated from 11400-Series Oscilloscope Calibrator output. Probe Tip TC 100 ppm/°C			
	Volts/Division	ΔV DC Accuracy	DC Balance	DC Offset Accuracy
	100 mV to 10 V/div	±(0.6% + 0.01 div)	±(5 mV + 0.1 div)	±(0.15% + 4 mV)
	With P6156 Probe calibrated from 11400-Series Oscilloscope Calibrator output. With Option 26, 500 Ω 10X Probe Tip.			
	Volts/Division	ΔV DC Accuracy	DC Balance	DC Offset Accuracy
	100 mV to 10 V/div	±(1.0% + 0.05 div)	±0.2 div	±(0.50% + 0.01 div)
	With P6156 Probe calibrated from 11400-Series Oscilloscope Calibrator output. With Option 27, 1000 Ω 20X Probe Tip.			
	Volts/Division	ΔV DC Accuracy	DC Balance	DC Offset Accuracy
200 mV to 20 V/div	±(1.0% + 0.05 div)	±0.2 div	±(0.50% + 0.01 div)	
With P6156 Probe calibrated from 11400-Series Oscilloscope Calibrator output. With Option 28, 5000 Ω 100X Probe Tip.				
Volts/Division	ΔV DC Accuracy	DC Balance	DC Offset Accuracy	
1 V/div	±(1.0% + 0.05 div)	±0.2 div	±(0.50% + 0.01 div)	
2 V to 100 V/div	±(2.0% + 0.05 div)	±0.2 div	±(1.50% + 0.01 div)	

¹For absolute DC accuracy of single-point measurements using Offset, add the DC Offset Accuracy, DC Balance and ΔV DC Accuracy terms.

Table 4-5 – Electrical Characteristics of the 11A72 Amplifier in 11400-Series Oscilloscopes (cont)

Characteristic	Performance Requirement		
Frequency Response	High Frequency Limit (the -3 dB point) and Calculated Rise Time for the Display, Auxiliary and Trigger signals. Low Frequency -3 dB point :1 kHz maximum from 50 Ω source with AC coupling (V DC ≤ 20 V), temperature 0°C to 30°C		
	Volts/Division	11401 Oscilloscope	11402 Oscilloscope
	All	500 MHz Bandwidth 0.7 ns Calc Rise time	1000 MHz Bandwidth 0.35 ns Calc Rise time

MANUAL CHANGE INFORMATION

At Tektronix, we continually strive to keep up with latest electronic developments by adding circuit and component improvements to our instruments as soon as they are developed and tested.

Sometimes, due to printing and shipping requirements, we can't get these changes immediately into printed manuals. Hence, your manual may contain new change information on following pages.

A single change may affect several sections. Since the change information sheets are carried in the manual until all changes are permanently entered, some duplication may occur. If no such change pages appear following this page, your manual is correct as printed.